

RMV-11M

- * 4008 x 2672* CL or GE
- * Progressive scan CCD camera



quality
innovation
reliability
performance



The RMV-11M is a 4,008(H) x 2,672(V) 11 Mega pixel digital camera used in industrial machine vision, military, and scientific market applications. Designed from the ground up with the latest technologies, this camera represents a new standard in digital imaging. The RMV-11M offers additional features such as: full 12 bit sampling and data paths, advanced triggering and CCD readout control, built in detectors that analyze the camera's performance, image processing to remove sensor defects, and on screen tools for analyzing line/columns and text overlay.

The Truesense Imaging Inc KAI-11002 image sensor is a 11 mega pixel progressive scan interline CCD image sensor in a 35mm optical format (43.3 mm diagonal).

The RMV-11M provides extreme performance at a very affordable price!

Highlights:

- 4008 x 2672 pixels with 9.0 um pixel size
- Monochrome, Bayer Color
- Global electronic shutter
- Full 14 bit sampling
- 8, 10, 12 bit selectable data output
- >66 dB dynamic range
- On Screen text and line plots
- Extended temperature range of -50C to +85C
- Military rated design
- Pixel and column defect correction
- Industrial components
- Camera control GUI
- Binning modes
- Partial scan mode for higher frame rate
- Selectable clock speed
- Digital gain and offset
- Camera Array Communications control
- Many customized features!

RMV-11M Specifications

Sensor	Truesense Imaging Inc KAI-11002
Architecture	Interline CCD, progressive Scan
Configuration	Mono, Bayer color
Active pixels	4008(H) x 2472 (V)
Pixel size	9.0 x 9.0 μ m
Active image size	35mm format (43.3mm diag)
Outputs	1 or 2
Frame rate @ 30 Mhz	5 fps
Dynamic range	66 dB
Clock speed	20, 32MHz. 48MHz optional
Blooming suppression	> 1000x
Electronic shutter	> 1/5000 sec (Global)
Smear	-80 dB
Read noise (f=32MHz)	30 electrons
Binning	1-16x Horizontal and Vertical
Partial scan	Any line to any line
Trigger modes	Free run, Free Run Synchronized, Triggered Program Exposure (TPE) Triggered Double Exposure (TDE) Triggered Overlap Exposure (TOE) Triggered Manual Exposure (TME)
Mount options	F-mount, Flange, OEM configuration Canon mount, Hasselblad mount, Birger mount
Power with fan	6.0W @ 12VDC
Operating Temp	-50C to +85C (camera link)
Weight without lens	16.2 oz (470 grams)
Options	Call for OEM options

Software

All illunis cameras come with our free control application, which allows interactive setup of all camera parameters. The cameras can be configured using any terminal software that supports serial communication.

We specialize in custom OEM camera designs. Call us today to find out what we can do for you!

illunis LLC
14700 Excelsior Blvd
Minnetonka, MN 55345
USA

Phone: 952.975.9203
Fax: 952.294.8308
email: info@illunis.com
web: www.illunis.com

illunis Europe
Minervum 7069
4817 ZK Breda
The Netherlands

Phone: +31 76-544 0588
Fax: +31 76-541 7893
email: sales@illunis.eu
web: www.illunis.com

Dimensions

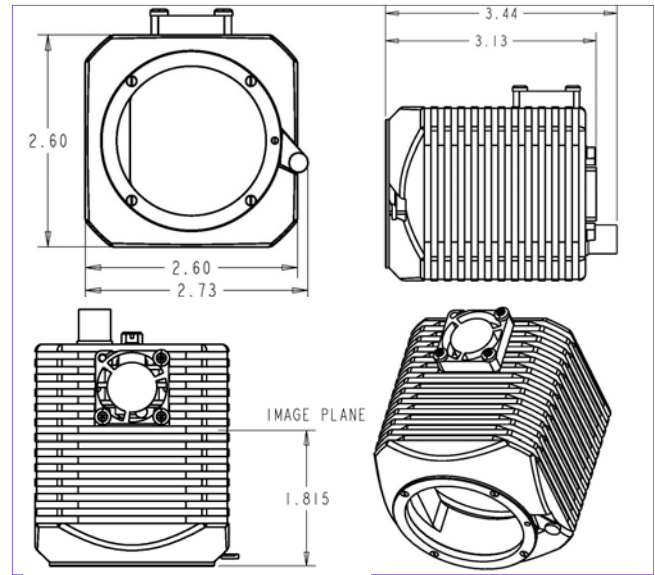

Applications

Aerial imaging
LCD inspection
Scientific imaging
Portrait photography
Traffic management
Military applications
Persistent Surveillance
PCB inspection

