

4

3

2

1

REVISIONS			
LTR	DESCRIPTION	DATE	APPR
A	Release	10/26/06	STE

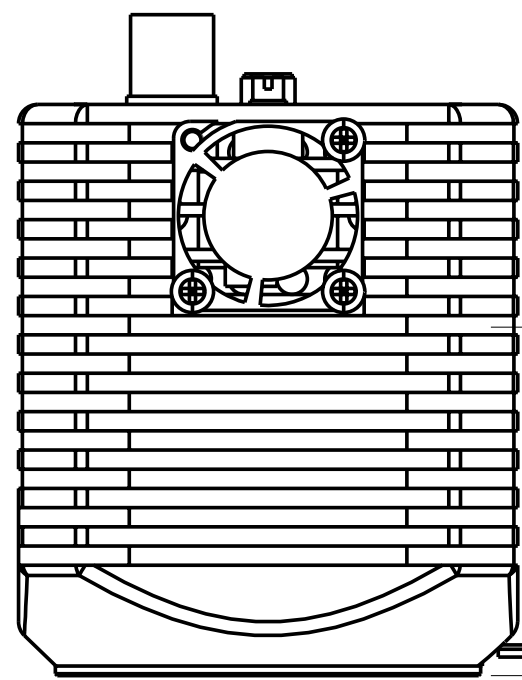
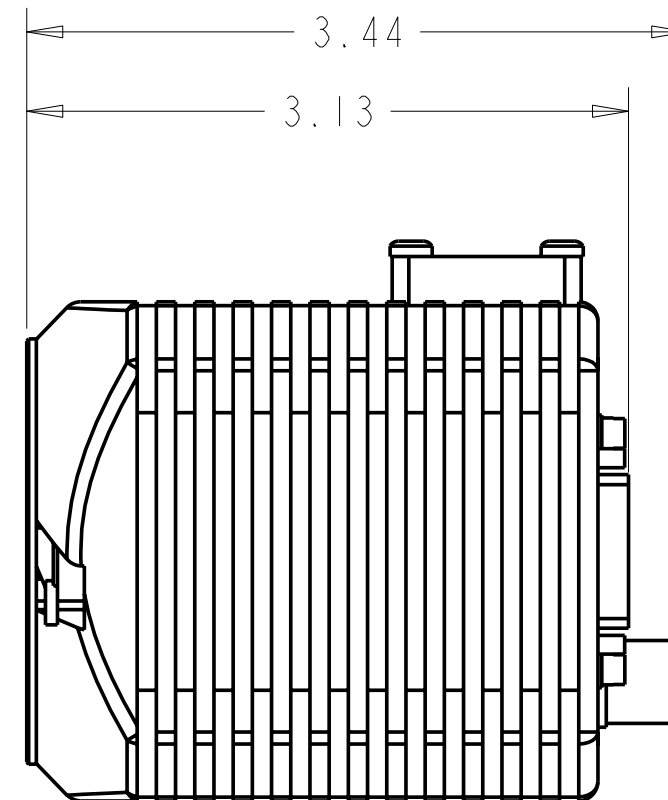

IMAGE PLANE

1.815



3.44

3.13

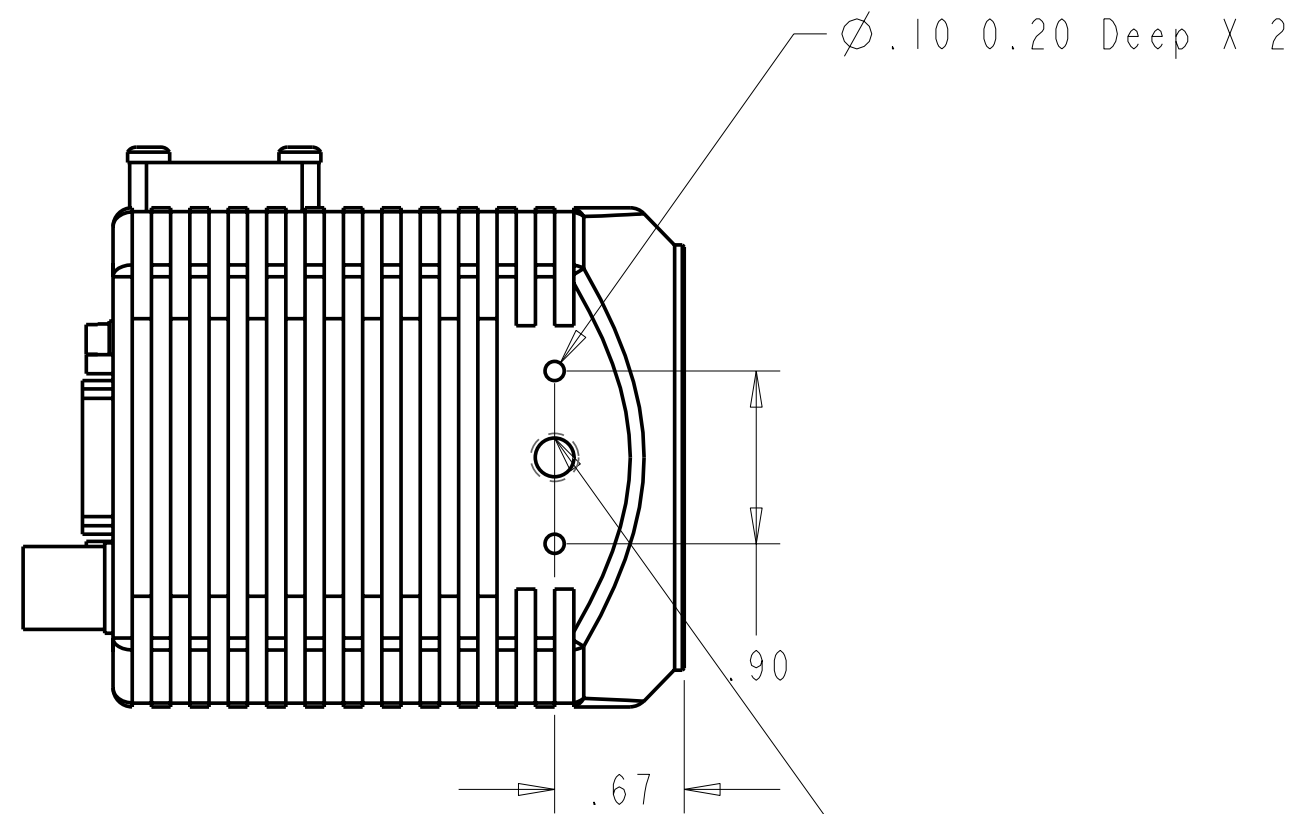

Ø.10 0.20 Deep X 2

.90

.67

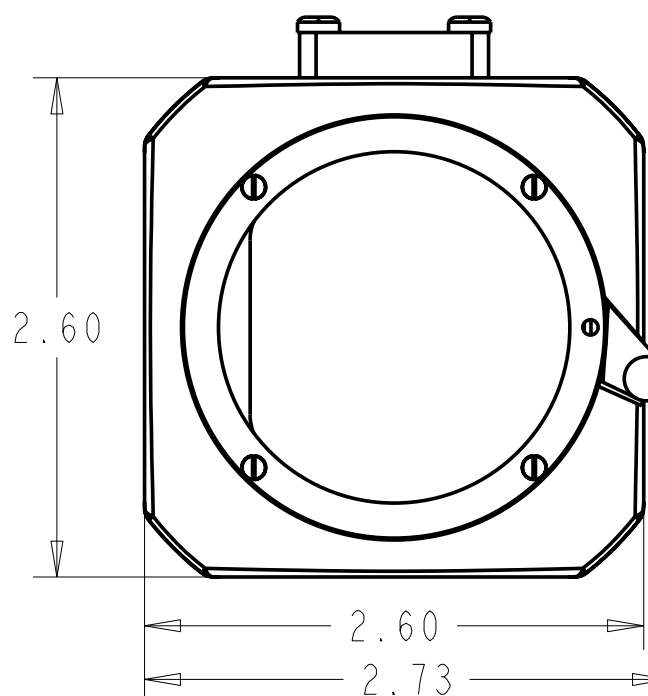

2.60

2.60

2.73

1/4-20 UNC - 2b TAP ∇ 0.350
 #7 DRILL (0.201) ∇ 0.400 - (1) HOLE

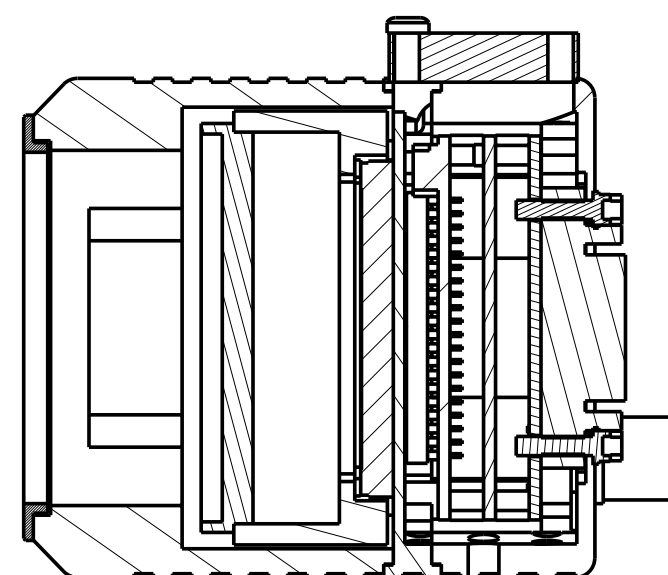
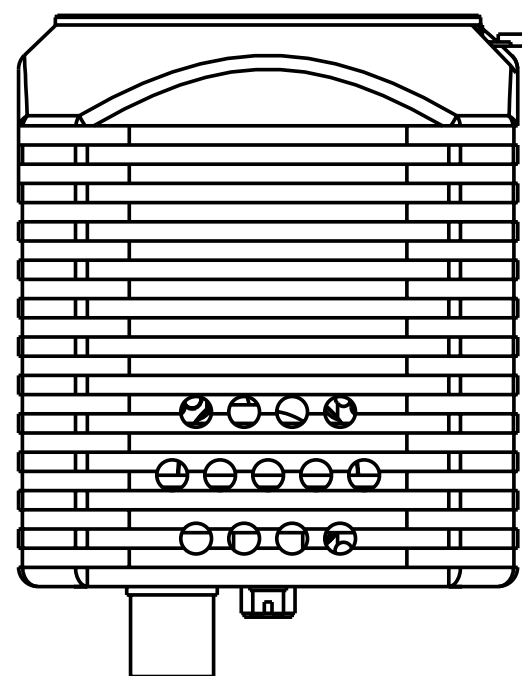

SECTION XSEC0001-XSEC0001

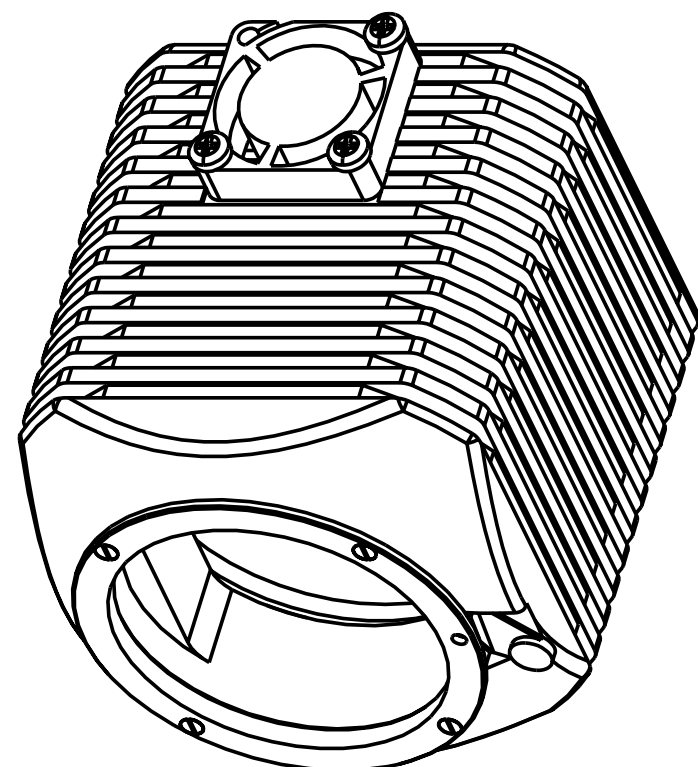

UNLESS OTHERWISE NOTED LINEAR DIMS. IN INCHES.		CONTRACT NO.		TITLE XMV .11M STD.F.FAN 890113 B	
TOLERANCES		DRAWN STE			
DECIMAL		CHECK STE			
.XX+/-		DES STE			
.XXX+/-		ENGR STE			
DO NOT SCALE DRAWING		O.A. STE		DWG SIZE C	
TREATMENT		MFG. STE			
FINISH		DESIGN ACTIVITY STE		CAGE CODE	
NEXT ASSY USED ON		CUSTOMER		DWG NO. 890113	
APPLICATION		WEIGHT		REV. B	
				SCALE .000	
				REL. DATE 10/25/06	
				SHEET 1 OF 2	

D

C

DWG NO. 890113

SH 1 REV B

A

REVISIONS			
LTR	DESCRIPTION	DATE	APPR

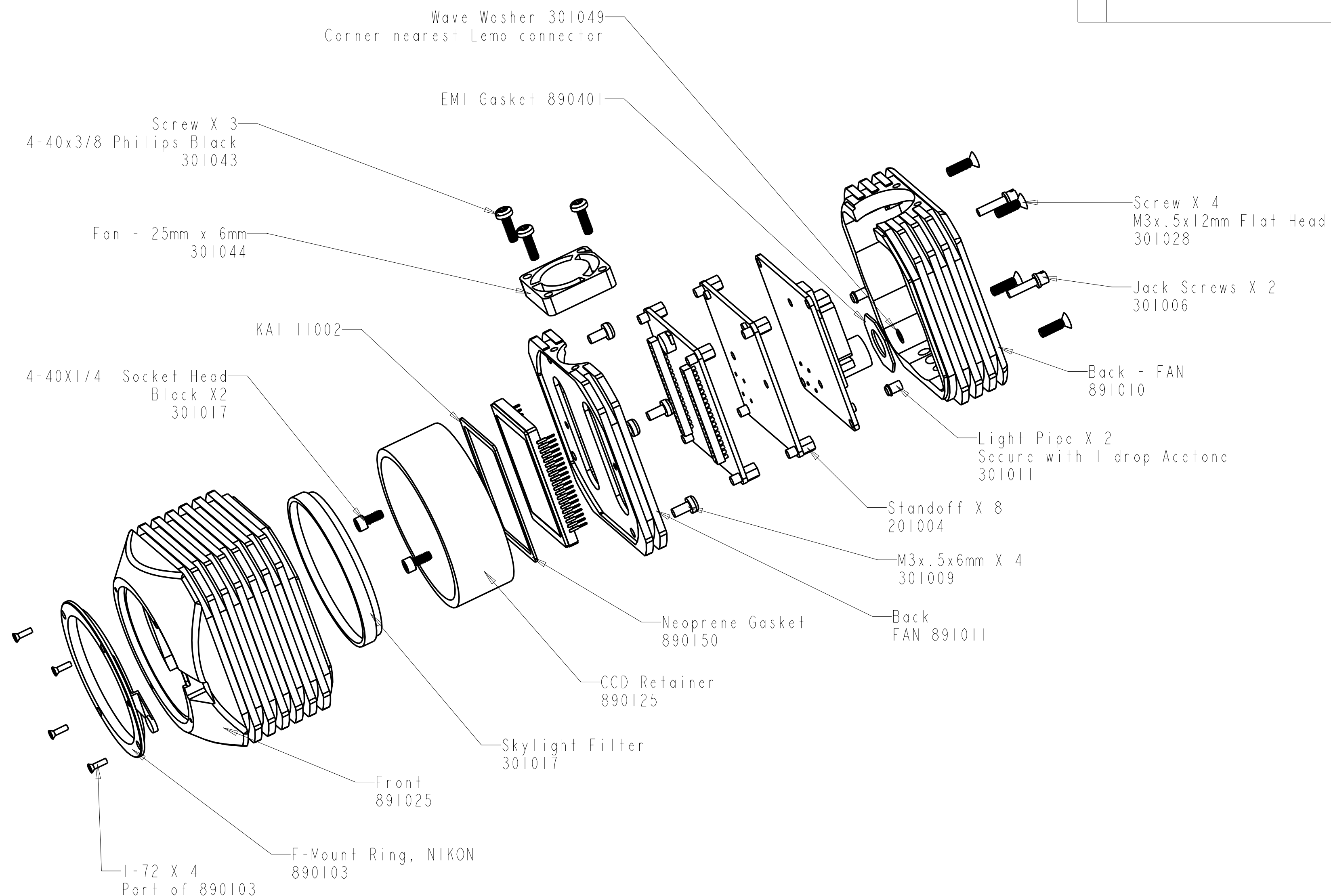

D

C

DWG NO. 890113

SH 2 REV B

A

UNLESS OTHERWISE NOTED LINEAR DIMS. IN INCHES. TOLERANCES DECIMAL .XX+/- .XXX+/-		CONTRACT NO.		TITLE	
FINISH ANGULAR +/-		DRAWN STE			
DO NOT SCALE DRAWING		CHECK STE			
TREATMENT		DES STE			
FINISH		ENGR STE			
NEXT ASSY USED ON		O.A. STE		DWG SIZE C	
APPLICATION		MFG. STE		CAGE CODE	
WEIGHT		DESIGN ACTIVITY STE		DWG NO. 890113	
		CUSTOMER		REV. B	
				SCALE .000 REL. DATE 6/14/06 SHEET 2 OF 2	