

Copyright 2017 illunis LLC  
 All rights reserved. This material contains CONFIDENTIAL INFORMATION that is the property of illunis LLC. Any use, duplication or disclosure not specifically authorized in writing by illunis LLC is prohibited.

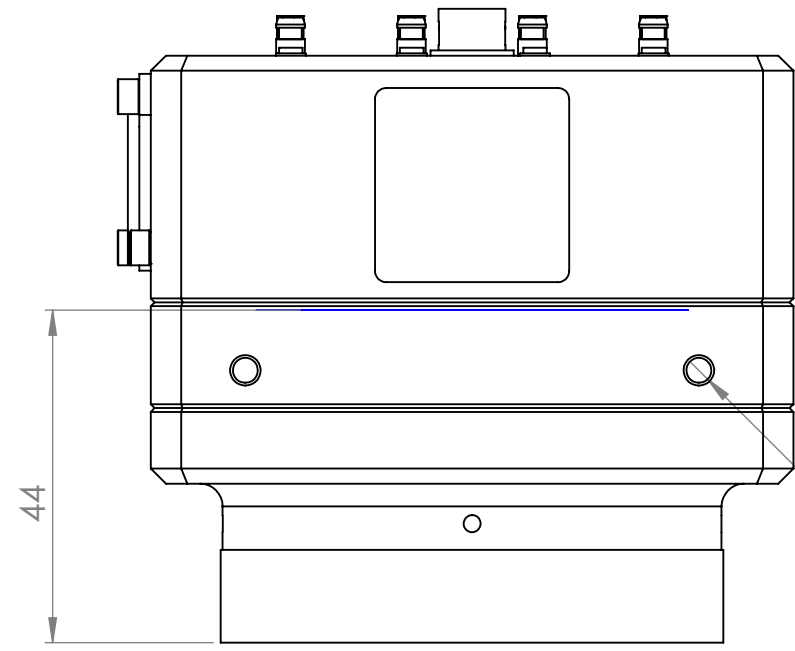

8 x  $\phi$  3.30  $\nabla$  7.10  
 M4x0.7 - 6H  $\nabla$  5  
 $\phi$  4.05 X 90°, Near Side

44

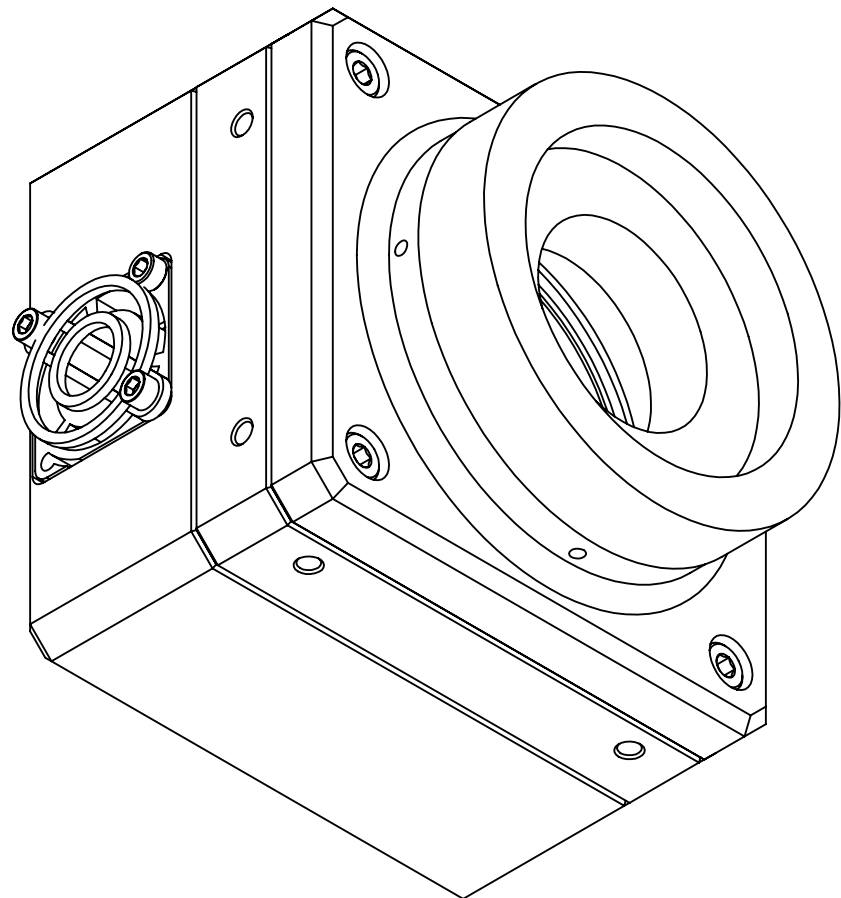
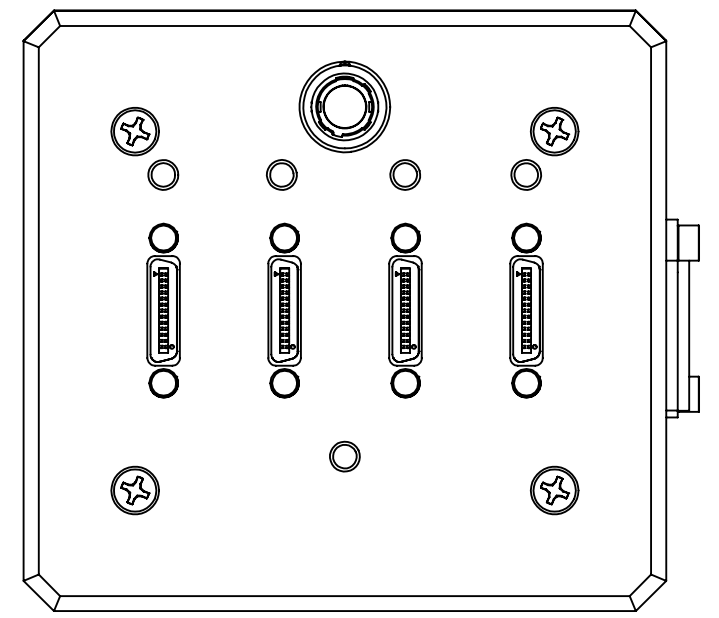
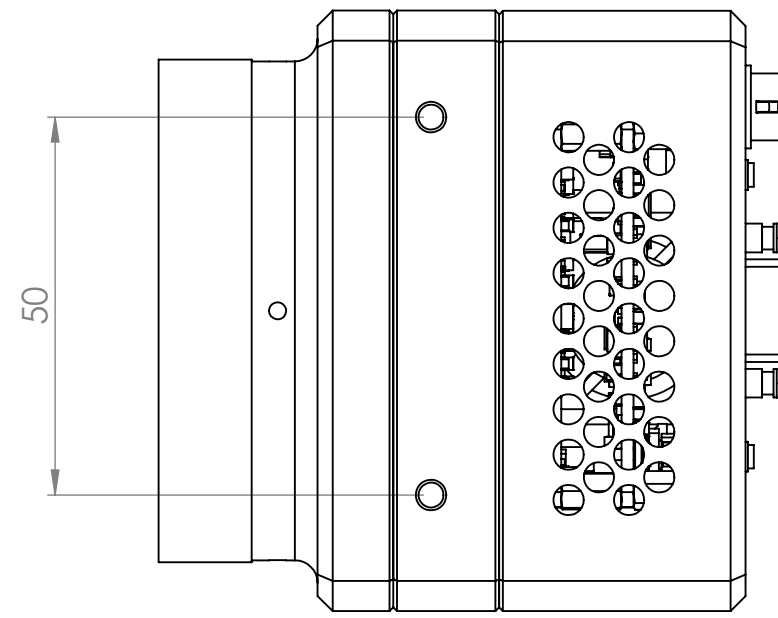
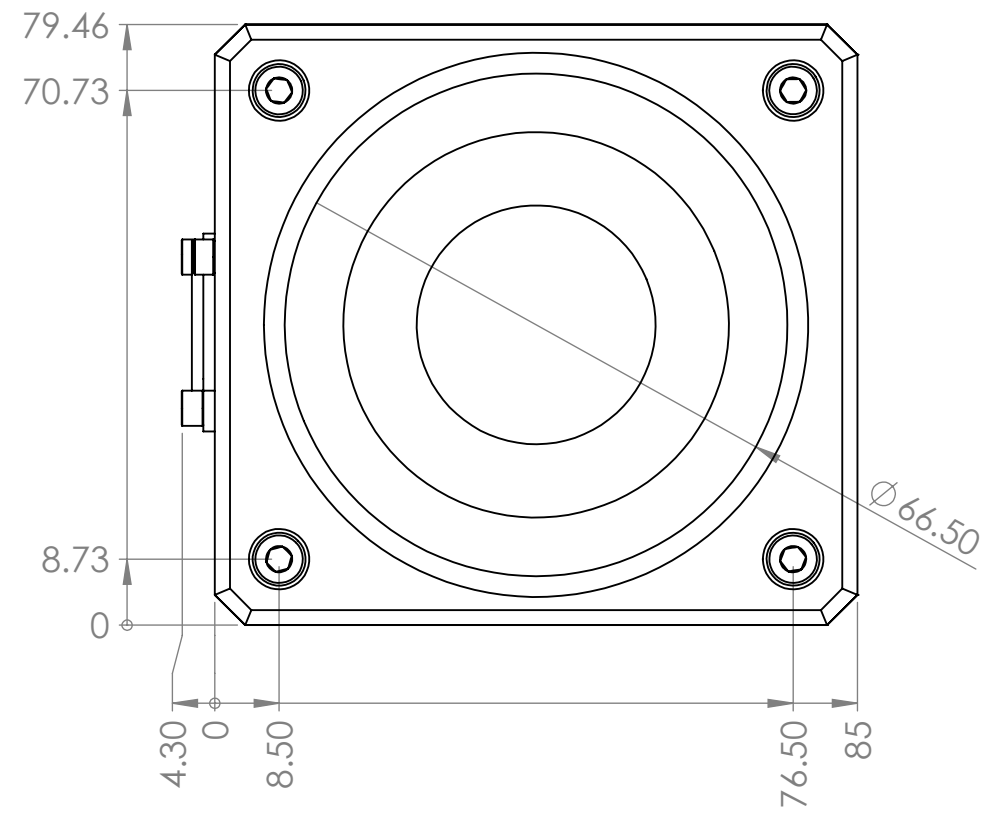
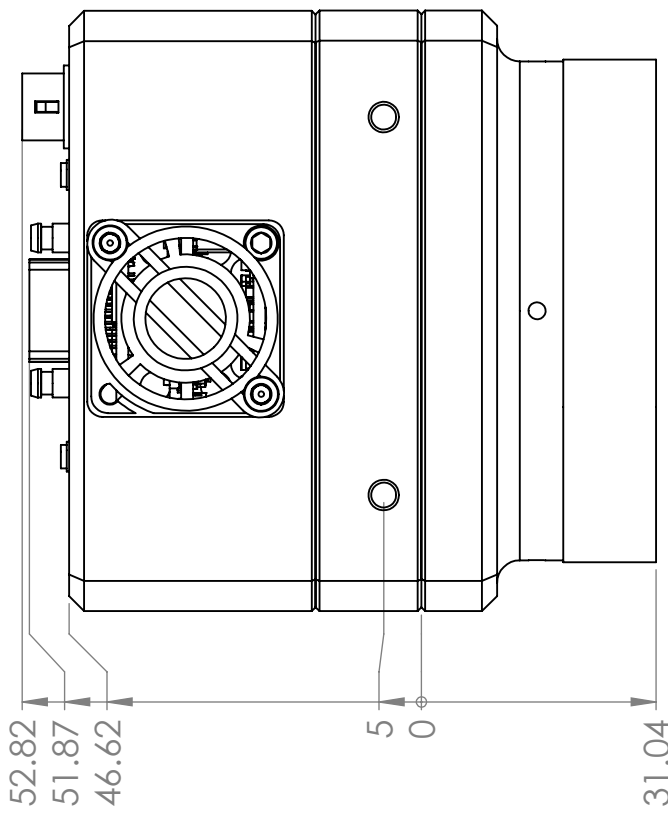

UNLESS OTHERWISE SPECIFIED  
 DIMENSIONS ARE IN mm [in]  
 TOLERANCES ARE:  
 DIMENSIONED ANGLES  $\pm$  0.5°

DECIMAL mm  
 0-30  $\pm$  .1  
 31-120  $\pm$  .2  
 121-350  $\pm$  .4  
 351-1000  $\pm$  .8

DECIMALS in  
 .X  $\pm$  .020  
 .XX  $\pm$  .010  
 .XXX  $\pm$  .005

	BY	DATE
DESIGNED		
DRAWN		4/25/2016
CHECKED		

**illunis LLC**  
 14700 Excelsion Blvd  
 Minnetonka, MN 55345  
 952-975-9203

TITLE:

MACHINING REQUIREMENTS:  
 EDGE BREAKS TO BE 0.2mm [0.015in] MAX  
 REMOVE ALL BURRS AND SHARP EDGES

MATERIAL  
 DO NOT SCALE DRAWING



SIZE	PART NO.	REV
<b>C</b>		
SCALE: 1:1	WEIGHT:	SHEET 1 OF 1